

RIGADO

Cascade-500 Series Gateway User Manual



Contents

Introduction	2
1 Planning.....	3
1.1 Coverage.....	3
1.2 Connections.....	3
1.3 Placement.....	3
2 Gateway Hardware.....	4
2.1 Specifications.....	4
2.2 Electrical Specifications	6
2.3 Interfaces.....	7
3 Mechanical Information	10
3.1 Cascade-500 and Cascade-500-A Dimensions.....	10
3.2 Cascade-500-W and Cascade-500-X dimensions	10
4 Installation.....	11
4.1 Equipment	11
4.2 Mounting Tools	11
4.3 Mounting Instructions.....	12
4.4 Hole Drilling Template.....	14
5 Gateway Setup.....	15
5.1 Initial Boot	15
5.2 Edge Direct Connection.....	15
5.3 Troubleshooting	16
6 Regulatory Information.....	17
6.1 Authorized Countries and Territories.....	17
6.2 FCC Statement.....	19
6.3 IC Statement.....	20
6.4 CE Statement	20
6.5 RF Exposure Statement	21
6.6 Non-modification Warning Statement.....	21
6.7 Taiwan (NCC) Statement	21
6.8 Open Source	21
6.9 Product Insert – Compliance Information.....	22

Introduction

Cascade-500 series Gateways are part of Rigado's Cascade Edge-as-a-Service solution that offer powerful and cost-effective edge network infrastructure for large-scale, low-power wireless deployments. Cascade gateways provide commercial and enterprise IoT project and product teams with flexible edge computing power, a robust containerized application environment, and a variety of wireless device connectivity options.

Models included in this document	
Cascade-500	Edge Gateway with [®] , Wi-Fi, and Ethernet connectivity
Cascade-500-A	Edge Gateway with Bluetooth [®] , Wi-Fi, and Ethernet connectivity (Alternate SKU for Cascade-500 with improved availability)
Cascade-500-W	Edge Gateway with Bluetooth [®] , Wi-Fi, Ethernet, and LTE Cat1/3G/2G cellular connectivity. Not Recommended for New Designs (NRND).
Cascade-500-X	Edge Gateway with Bluetooth [®] , Wi-Fi, Ethernet, and LTE Cat1/3G/2G cellular connectivity (Alternate SKU for Cascade-500-W with improved availability)

Revision History

Version	Description	Date
V1.0	Initial Release	2018-08-21
V1.1	Add regulatory statements; sections 6.4 and 6.5	2019-09-11
V1.2	Added interface drawing and descriptions for Cascade-500-W	2019-09-13
V1.3	Clarify cellular info in section 2.1	2019-09-18
V1.4	Updated regulatory information in sections 2 and 6	2020-06-17
V1.5	Updated regulatory statement; section 6.4	2020-09-22
V1.6	Updated operating temperature and mounting guide	2021-03-24
V1.7	Updated electrical specifications (section 2.2.2) and country list (section 6.1)	2021-05-25
V1.8	Update country list in regulatory section (section 6.1), added insert (section 6.9), updated power consumption in section 2.2.3. Minor formatting throughout.	2021-08-25
V1.9	DRAFT - Add regions and regulatory details to compliance sections (sections 2.1 and 0). Add details for Cascade-500-A and Cascade-500-X	2022-06-09
V1.10	Updated Rigado address, FCC statement, and IC statement. Added note about operation through extended temperature range, and additional certified countries in 2.1 and 6.1, and 6.9. Changed Bluetooth [®] references to the latest branding guidelines. Added notes about Cascade-500-W Not Recommended for New Designs.	2023-02-14
v.1.11	Added New Zealand certification to C500X	2023-05-12
v.1.12	Added additional IC statement	2023-06-05
v.1.13	Minor text changes to support Oman certification	2023-08-22
v.1.14	Updated Rigado address, consolidated the FCC Responsible Party data into 1 section, added EU Economic Operator requirements to the CE statement, updated the product inserts, added additional certifications and certified countries, backed out Oman specific change from ver 1.13.	2023-01-15
v.1.15	Table in 6.1 changed to add Turkey for Cascade-500-A and Cascade-500-X, removed Cascade-500 Brazil, Israel, Azerbaijan, and Vietnam and made corresponding changes in the Certifications section.	2024-06-05
v1.16	Table in 6.1 changed to remove India from C500 and add India to C500-X, Warning statement on not using both POE and barrel jack power simultaneously added to 2.3.1 and 2.3.4, removed Brazil(Anatel) statement	2024-08-22
V1.17	Updated supported countries, added section 6.8 OSS licensing URL	2025-03-06

1 Planning

Planning is key to the success of any hardware installation. There are many things to consider when installing a wireless system into a space. Key elements for consideration are listed in the sections below.

1.1 Coverage

In a typical commercial space expected coverage area is about 4,000 sq. ft. per Gateway. However, the area of coverage for each Gateway is dependent on the layout and construction of the facility where it is installed. A Gateway in an open floor plan will have a larger coverage area than a closed floor plan with many walls. Building construction materials also affect coverage – drywall and glass permit more coverage than brick and concrete. Note that brick or concrete walls should be planned around, as signals have poor penetration through these types of walls. If coverage is required on both sides of a brick or concrete wall, plan for a Gateway on each side.

If a higher level of coverage planning precision is required, Rigado suggests using a Wi-Fi site planning tool to simulate coverage. There are multiple planning tools available online, both free and professional. For use in this application, it should allow for changing the Access Points transmit power and characteristics for the Rigado Gateway.

1.2 Connections

Connectivity is an important consideration when planning a new installation. To function properly, the Gateway needs both power and internet connection. For power, the options are Power over Ethernet (PoE) or AC wall power (adapters available upon request). For internet connection, the options include Wi-Fi, Ethernet, or LTE (Cascade-500-W and Cascade-500-X only).

Rigado suggests using PoE-enabled Ethernet for the Gateway connection. PoE provides both power and data to the Gateway with only one cable for installation. When using Wi-Fi or LTE connectivity network credentials need to be pre-loaded onto gateways before installation on site.

1.3 Placement

Correct placement of Gateways is important in achieving the desired coverage. Generally, mounting Gateways up high and out of reach is recommended, as this improves line of sight while decreasing the likelihood of physical tampering. Avoid mounting gateways near large metal obstructions or objects – such as in support beams or HVAC ducts – as it is not recommended to mount the Gateway directly to any large metal surface.

Gateways do not need to be visible for operation. When mounting above drop ceilings or in open office style spaces, it is recommended to mount the Gateway below the level of any ceiling HVAC ducts to avoid dead spots.

2 Gateway Hardware

2.1 Specifications

Processor	
i.MX6ULL (Y2)	800MHz, 32bit ARM® Cortex™-A7
Memory	
Memory (Volatile)	512 MB DDR3L SDRAM @ 400MHz, x16
Memory (Bulk Storage)	8GB eMMC
Wi-Fi (802.11a/b/g/n/ac)	
Frequency	2.412GHz - 2.472GHz; 5.180GHz – 5.700 GHz (region dependent)
Modulations	DSSS, FHSS OFDM
Transmit Power	19dBm for 2.4GHz band, 18dBm for 5GHz band, depending on modulation
Receiver Sensitivity	-98 to -72dBm for 2.4GHz band, -92 to -68dBm for 5GHz band, based on modulation
Antenna	Integrated Dual-band Antenna
Bluetooth® Connectivity	
BMD-345 Module	
Bluetooth® Version	5.1 (Bluetooth® Low Energy)
LE Connections	Up to 6 connections supported
Frequency	2.402 to 2.480 GHz
Modulations	GFSK at 1Mbps, 2Mbps data rates
Transmit Power	12dBm
Receiver Sensitivity	-108 to -98dBm, depending on modulation
Cellular LTE Cat1 with 3G/2G fallback (Cascade-500-W only) – Not Recommended for New Designs	
LTE (E-UTRA FDD) Frequencies	700, 800, 850, 900, 1700/2100 (AWS), 1800, 1900, 2100, 2600 MHz (bands 1, 2, 3, 4, 5, 7, 8, 12, 18, 19,20, 28) (region dependent)
UMTS FDD Frequencies	800, 850, 900, 1700/2100 (AWS), 1800, 1900, 2100 MHz (bands I, II, IV, V, VIII, IX, XIX) (region dependent)
GSM/GPRS/EDGE Frequencies	GSM 850, 900, 1800, 1900 MHz
Modulations	GMSK/QPSK/16QAM
Power Class (per listed 3GPP release)	EGSM850/900: Class 4, GSM1800/1900: Class 1, according to release 99 GSM 850/900/1800/1900 8-PSK: Class E2, according to release 99 UMTS 800/850/900/AWS/1800/1900/2100: Class 3, according to release 99 LTE 700/800/850/900/AWS/1800/1900/2100/2600: Class 3 according to release 8
Antenna	Dual external dipole antennas, 5.0dBi
GPRS/EGPRS Multislot Class	12
Cellular LTE Cat1 with 3G/2G fallback (Cascade-500-X only)	
LTE (E-UTRA FDD) Frequencies	700, 800, 850, 900, 1700/2100(AWS), 1800, 1900, 2100, 2600 MHz (bands 1, 2, 3, 4, 5, 7, 8, 12, 13, 18, 19, 20, 26, 28, 66) (region dependent)
LTE (E-UTRA TDD) Frequencies	2300, 2500, 2600 (bands 38, 40, 41)
UMTS FDD Frequencies	850, 900, 1700/2100 (AWS), 1900, 2100 MHz (bands I, II, IV, V, VI, VIII) (region dependent)
GSM/GPRS/EDGE Frequencies	GSM 850, 900, 1800, 1900 MHz
Modulations	GMSK/QPSK/16QAM
Power Class (per listed 3GPP release)	EGSM850/900: Class 4, GSM1800/1900: Class 1, according to release 99 GSM 850/900/1800/1900 8-PSK: Class E2, according to release 99 UMTS 800/850/900/AWS/1800/1900/2100: Class 3, according to release 99 LTE 700/800/850/900/AWS/1800/1900/2100/2600: Class 3 according to release 8
Antenna	Dual external dipole antennas, 5.0dBi
GPRS/EGPRS Multislot Class	12

Ethernet		
10/100 Base-T RJ-45 connector with PoE Support		
USB		
USB 2.0, Type-A Host connector		
Dimensions		
Cascade-500 / Cascade-500-A Enclosure	Length	127 mm
	Width	127 mm
	Height	30 mm
Cascade-500-W / Cascade-500-X with cellular antennas	Length	196 mm
	Width	38 mm
	Height	13 mm
Weight		
Cascade-500 / Cascade-500-A	Unit	156 g
	Packaging	97 g
Cascade-500-W / Cascade-500-X	Unit	180 g
	Antennas (2)	79 g (39.5 g each)
	Packaging	218 g
Accessories	Power Supply (Wall Adapter)	80 g
	Mounting Kit	56 g
Hardware		
Power supply	4.5 to 5.5VDC, 2A max via Barrel Jack (5.5mm x 2.1mm)	36-57V (IEEE 802.3af) via Ethernet connector (RJ-45)
Temperature Range	0 to +60°C	
Certifications		
Cascade-500	FCC / ISED / CE-RED / RCM / MIC (Japan) / WPC / SUTEL / IMDA / NTC / UKCA / NCC (Nigeria) / CRA / NCC (Taiwan) / CMIIT / SIRIM / ICT (Qatar) / NBTC / KCC	
Cascade-500-A	FCC / ISED / CE-RED / UKCA / RCM	
Cascade-500-W	FCC / ISED / CE-RED / UKCA / RCM / GCF / PTCRB / AT&T	
Cascade-500-X	FCC / ISED / CE-RED / UKCA / RCM / NOM / IFT / Kvalitet Mark (Serbia) / PTCRB / AT&T	

2.2 Electrical Specifications

2.2.1 Operating Conditions

Symbol	Parameter	Min.	Typ.	Max.	Unit
V _{AUX}	Operating supply voltage at barrel jack	4.5	5.0	5.5	V
V _{POE}	Operating supply voltage at Ethernet connector (PoE)	36	48	57	V
T _A	Operating ambient temperature	0	25	60	°C
T _{A-EXT}	Extended operating temperature range ⁵	-20	25	70	°C

2.2.2 USB Connector Power

Symbol	Parameter	Min.	Typ.	Max.	Unit	
V _{USB}	Operating output voltage at USB connector for loads up to 500mA ¹	Cascade-500(-W)	4.0	4.3	5.5	V
		Cascade-500-A/X	4.5	4.8	5.5	V

2.2.3 Power Consumption

Symbol	Parameter	Min.	Typ.	Max.	Unit
P _{POE}	Power consumption ² referenced at PoE input	1.8	2.5	5.6	W

2.2.4 Absolute Maximum Ratings³

Symbol	Parameter	Min.	Max.	Unit
V _{AUX_MAX}	Voltage at barrel jack ⁴	-5	12	V
V _{POE_MAX}	Voltage at Ethernet connector (for PoE)	-0.3	60	V
T _S	Storage temperature	-20	70	°C

1. USB is an output only – do not attempt to power the unit via the USB connector
2. Power consumption is dependent upon unit configuration (SKU) and application. Numbers provided in this table describe a Cascade-500-W unit connected to a cellular network, powered over Ethernet, without USB load.
3. Do NOT operate the unit under these conditions.
4. The unit will NOT operate over this voltage range. Prolonged exposure to these conditions is NOT recommended.
5. Operating over the extended temperature range may result in reduced performance.

2.3 Interfaces

Interface features are described throughout this section, including power and data connectivity, and button and LED location and behavior.

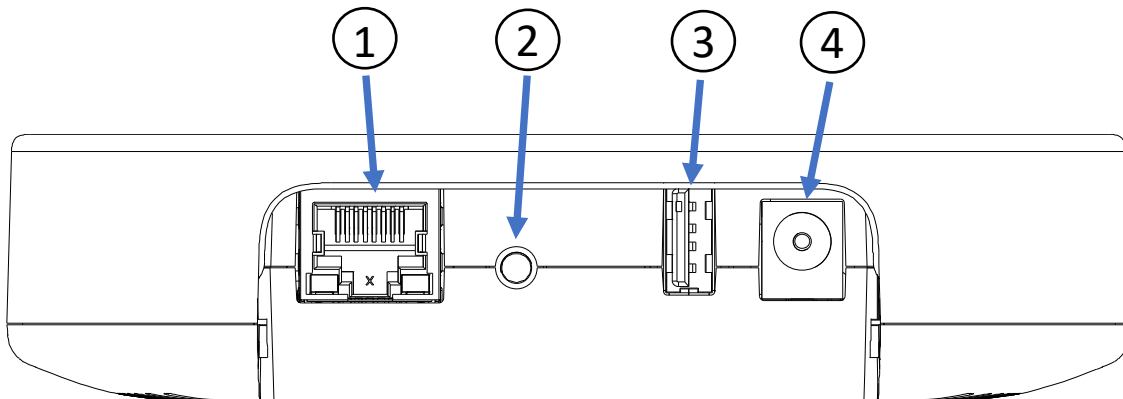

Figure 1 – Cascade Gateway – Back View

2.3.1 Ethernet with Power over Ethernet support

The Gateway is equipped with a single 10/100 Base-T Ethernet connector. For configurations supporting PoE (802.3af), the Gateway will operate when powered by either a PoE switch (end-span) or injector (mid-span).

Warning: The gateway must not be powered using POE at the same time as with an AC/DC wall adapter (described in section 2.3.4). Doing so may cause permanent damage not covered under warranty.

2.3.2 Reset Button

The reset button provides both soft and hard reset capabilities, depending on the length of the press. The timing is described in the following table:

Reset Action	Time	Behavior
Quick Press	< 2 seconds	Soft Reboot
Short Press	2-4 seconds	Network Reset
Long Press	10-15 seconds	Hard Reset
Very Long Press	> 30 seconds	Factory Reset

2.3.3 USB

A USB 2.0 Type-A connector on the Gateway board provides access to a High Speed (up to 480Mbps) USB host.

2.3.4 Barrel Jack

The Gateway provides a 5.5mm x 2.1mm barrel jack for 5V DC input. Any AC/DC wall adapter used to power the gateway must be rated up to 2A. Please note that actual current consumption is dependent upon the software deployed on the Gateway.

Warning: The gateway must not be powered using an AC/DC wall adapter at the same time as with POE (described in section 2.3.1). Doing so may cause permanent damage not covered under warranty.

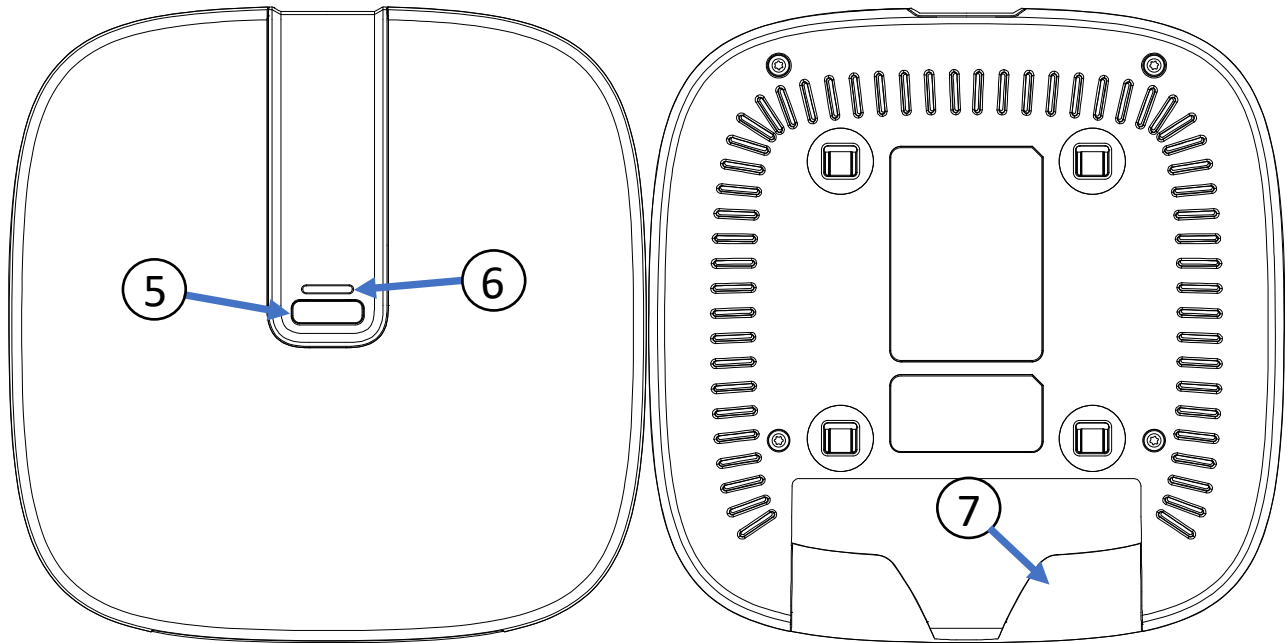

Figure 2 - Cascade Gateway - Top and Bottom View

2.3.5 Front Button

A front facing button is located on the face of the Gateway. This button is not enabled on the default Gateway configuration.

2.3.6 Multi-color LED

A multi-color (red/green/blue) LED located near the user button provides a means of visual indication for the user. For additional information regarding LED behavior, please refer to docs.rigado.com.

2.3.7 Cable Cover

The back of the unit has a snap-in cover for improved cable management. This allows for hidden cable routing when the unit is installed on a wall or ceiling. The cable cover is removable.

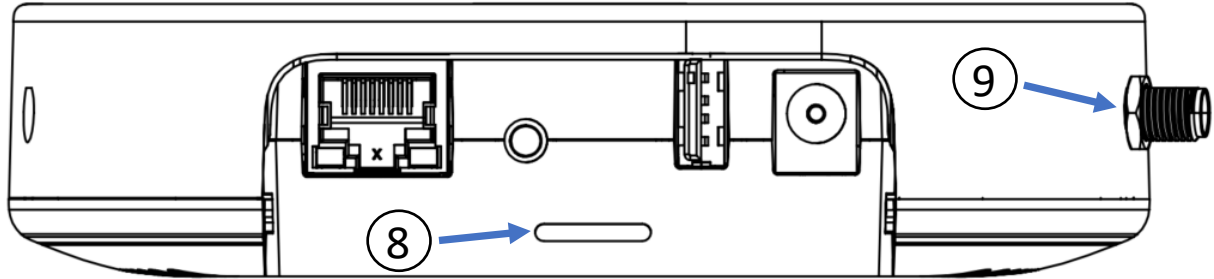

Figure 3 – Cascade-500-W/X Gateway – Back View

2.3.8 SIM Card Slot

Cascade-500-W and Cascade-500-X units also include a small slot on the back of the enclosure near the USB connector and reset button. This is a push-push type slot for a micro SIM (3FF).

2.3.9 Antenna Connector

Two SMA type connectors are visible on one side of the unit where the provided cellular antennas attach. Only antennas provided with the Cascade-500-W and Cascade-500-X unit are certified for use on cellular networks.

3 Mechanical Information

3.1 Cascade-500 and Cascade-500-A Dimensions

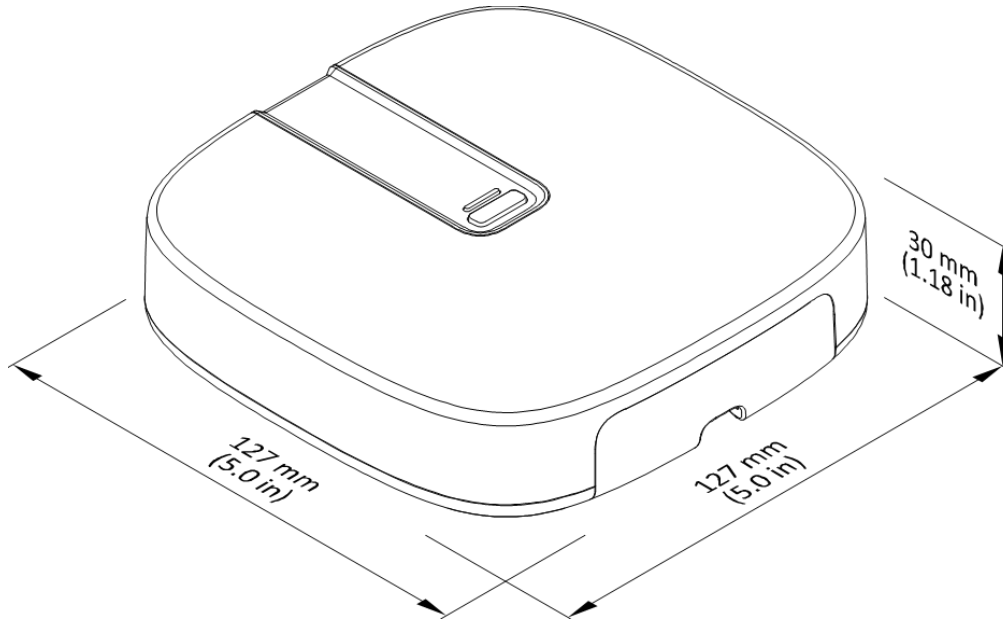

3.2 Cascade-500-W and Cascade-500-X dimensions

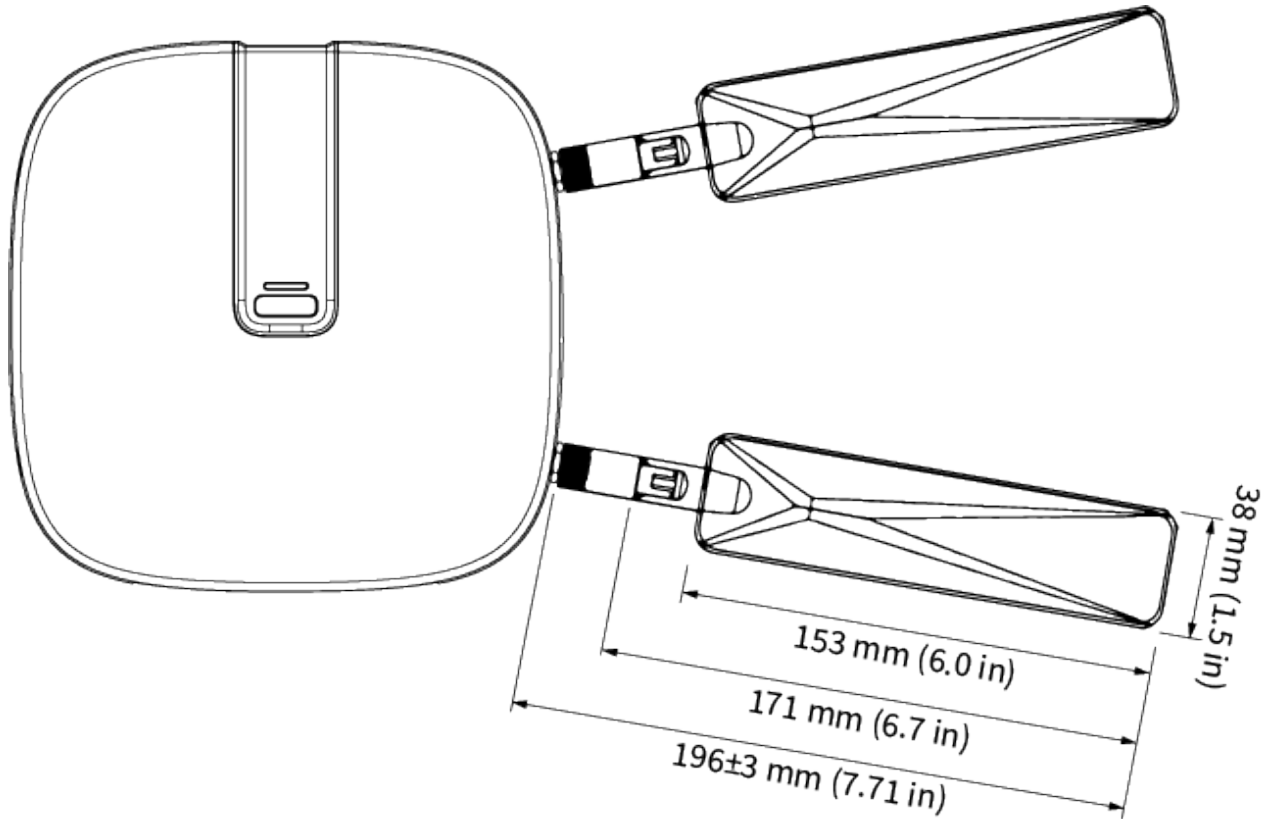

4 Installation

4.1 Equipment

Each Cascade Gateway comes with following equipment in the box:

- 1 x Cascade Gateway
- 2 x Cellular Antennas (Cascade-500-W and Cascade-500-X only)
- 1 x Power supply with international adapters (optional)
- 1 x Wall/Ceiling Mount Kit:
 - 1 x Cascade mounting bracket
 - 1 x Cascade ceiling backer plate
 - 4 x M3 x 50 mm Length, Pan Head, Phillips #1, Machine Screw
 - 4 x Screw, Pan Head Phillips Sheet Metal #6/18x1.25"
 - 4 x Drywall Anchor, #6 Screw, 1-1/4" Length

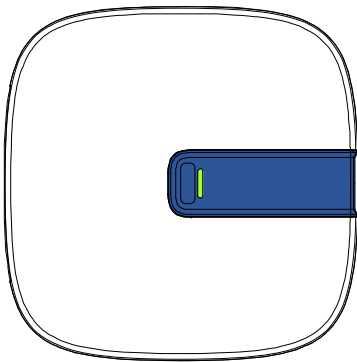

Cascade Gateway

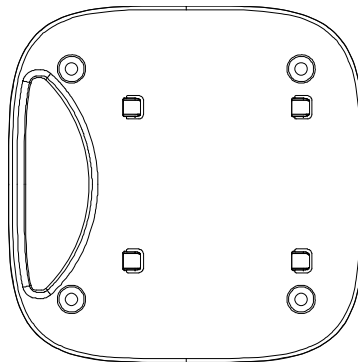

Mounting Bracket

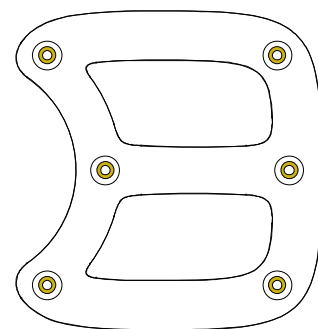

Ceiling Backer Plate

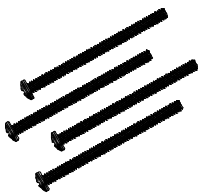

Ceiling Mount Screws
M3 x 50 mm Phillips (x4)



Wall Mount Screws
#6 x 1-1/4" Phillips (x4)

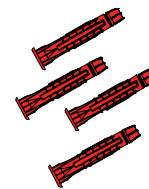

Drywall Anchors (x4)

4.2 Mounting Tools

To use the Wall/Ceiling Mount kit provided, the following tools are required (*not included*):

- Phillips screwdriver
- Drill and drill bit - 3/16" for wall, or 1/8" (3-4 mm) for ceiling mounting
- Drywall saw or keyhole saw for 1" cable pass-through hole

4.3 Mounting Instructions

Rigado recommends mounting the Gateway on a wall or ceiling, at least 6ft (2m) off the ground. If mounting on a wall, position the unit so that the connectors (USB, Ethernet, etc.) are facing down. This will ensure the mounting bracket attachment mechanism is secure against incidental removal.

1. Use the mounting bracket as a template to mark the hole locations on the wall or ceiling.
 - a. If mounting to the wall, use a 3/16" (5 mm) drill bit.
 - b. If mounting to a ceiling tile, use a 1/8" (3-4 mm) drill bit.

If a hole is needed for cable routing, also mark this in the appropriate cable opening space in the mounting bracket.

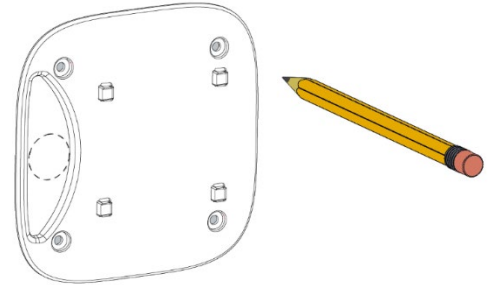

2. Attach the mounting bracket to the surface using the appropriate method:

Wall Mounting

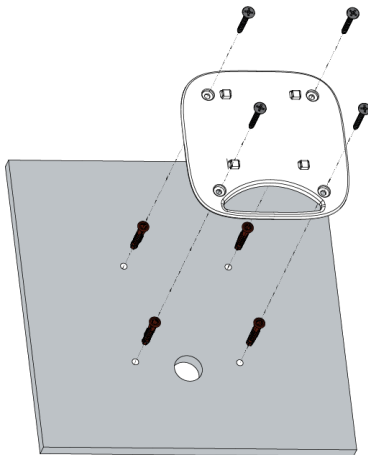

Push the provided drywall anchors into the drilled holes, then place the mounting bracket snugly against the wall. Using a screwdriver, screw the wall mount screws into the drywall anchors.

Ceiling Mounting

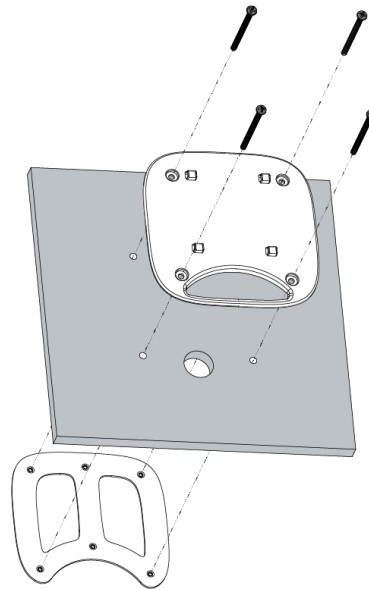

Place one ceiling mount screw through a mounting bracket screw hole, and push through the corresponding drilled ceiling hole. Use this screw to guide placement of the ceiling backer plate to the opposite side, then use the screwdriver to screw in this and the remaining ceiling mount screws.

3. Once the mounting bracket is installed, line up the four hooks of the mounting bracket with the corresponding holes on the back of the Gateway and press the two together. To lock in place, slide the Gateway over towards the cabling hole until it clicks into place.

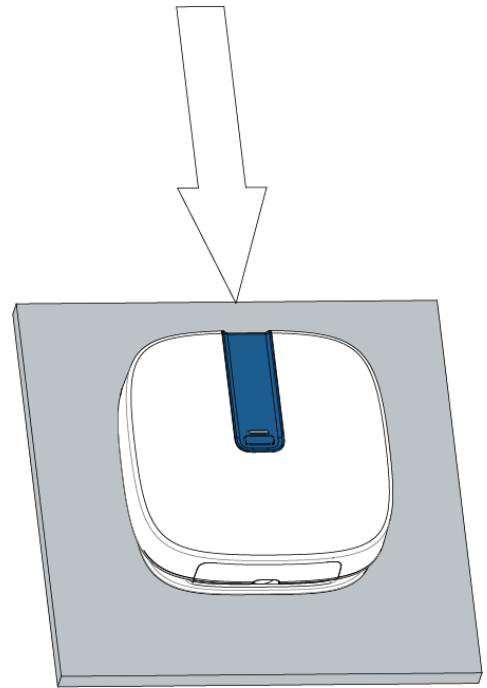
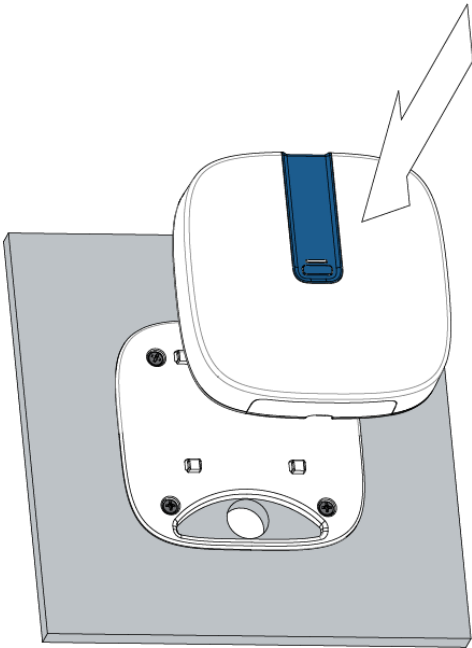

4.4 Hole Drilling Template

This template is at scale and can be printed for use.

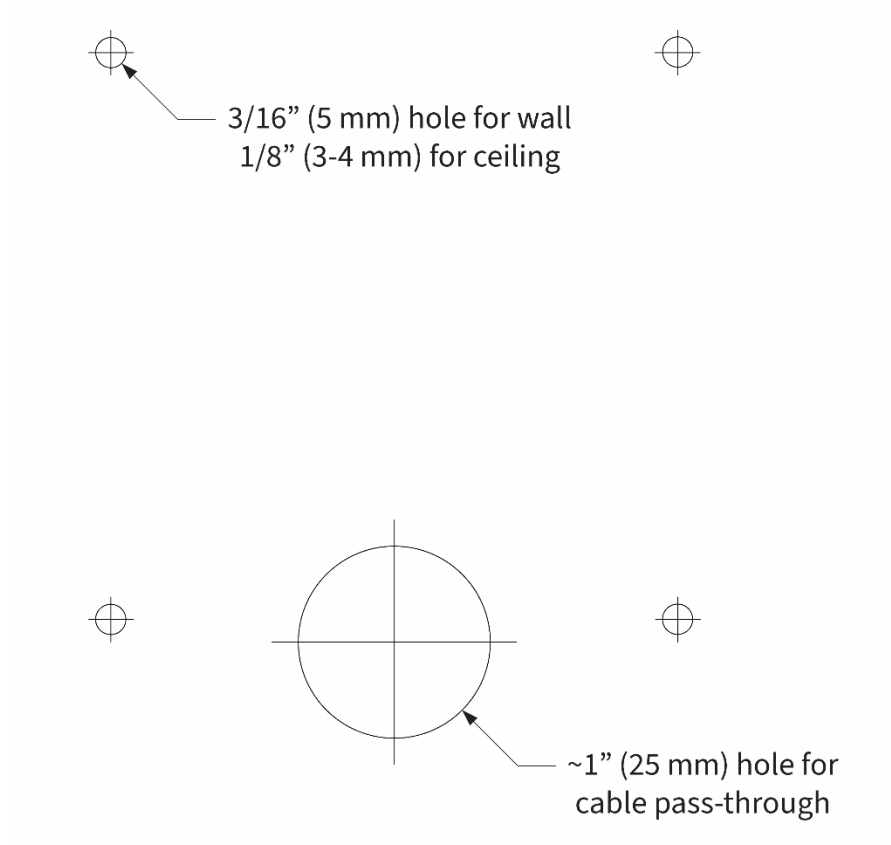

5 Gateway Setup

Before the Gateway is permanently installed, look at the bottom (mount side) and record the unit Serial Number (1) or scan the 2D barcode (2), as shown below.

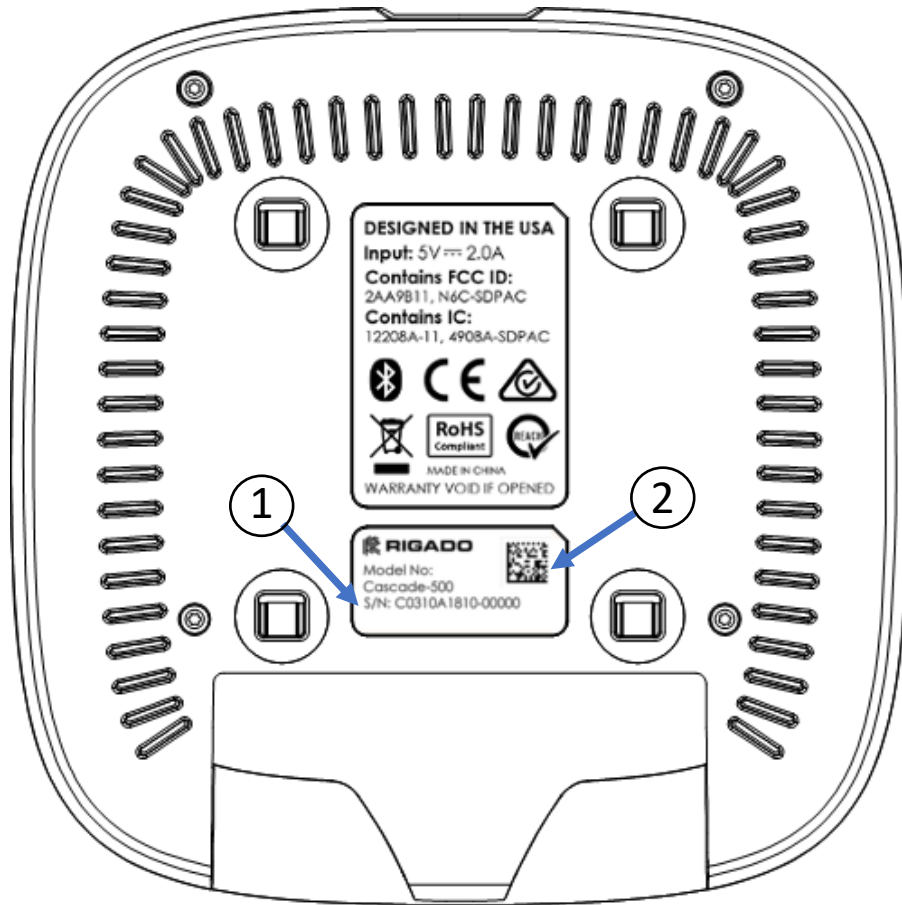

5.1 Initial Boot

At first power on, the Gateway’s LED indicator will display the boot status. The status of the Gateway can be determined using the following table:

LED color	LED activity	Status
Yellow/Amber	Solid	Appliance is booting
Yellow/Amber	Slow-blink (1 blink every 2 seconds)	Appliance is in provisioning sequence
Yellow/Amber	Fast-blink (2 blinks per second)	Provisioning is complete, appliance is authenticating
Green	Solid	Appliance is provisioned and authenticated with Rigado Edge Direct

5.2 Edge Direct Connection

Once the Gateway is successfully booted, it should show up on the [Edge Direct](#) homepage. To find the Gateway, navigate to ‘Gateways’ and look for the matching serial number. Select that unit and

a live status page will appear, showing current status and utilization. Edge Direct is the primary user interface for configuring the Gateway's applications and updates. For further details on Gateway configuration reference our Edge Direct documentation at docs.rigado.com.

5.3 Troubleshooting

Should you experience issues with any of the above steps, or with the Cascade-500 Gateways in general, please visit our technical documentation portal at docs.rigado.com. If you have an issue that is not resolved in our documentation, or if you have a more application-specific question, please reach out to us at support@rigado.com.

6 Regulatory Information

6.1 Authorized Countries and Territories

Each model of the Cascade-500 series is authorized for import into the following countries:

Region	Cascade-500	Cascade-500-A	Cascade-500-W	Cascade-500-X
United States	✓	✓	✓	✓
Canada	✓	✓	✓	✓
CE Certification (EU Region)	✓	✓	✓	✓
<i>Anguilla</i>	✓	✓	✓	✓
<i>Austria</i>	✓	✓	✓	✓
<i>Belgium</i>	✓	✓	✓	✓
<i>Bosnia & Herzegovina</i>	✓	✓	✓	✓
<i>Bulgaria</i>	✓	✓	✓	✓
<i>Comoros</i>	✓	✓	✓	✓
<i>Croatia</i>	✓	✓	✓	✓
<i>Cyprus</i>	✓	✓	✓	✓
<i>Czechia</i>	✓	✓	✓	✓
<i>Denmark</i>	✓	✓	✓	✓
<i>Estonia</i>	✓	✓	✓	✓
<i>Finland</i>	✓	✓	✓	✓
<i>France</i>	✓	✓	✓	✓
<i>Georgia</i>	✓	✓	✓	✓
<i>Germany</i>	✓	✓	✓	✓
<i>Greece</i>	✓	✓	✓	✓
<i>Guadeloupe</i>	✓	✓	✓	✓
<i>Hungary</i>	✓	✓	✓	✓
<i>Iceland</i>	✓	✓	✓	✓
<i>Ireland</i>	✓	✓	✓	✓
<i>Italy</i>	✓	✓	✓	✓
<i>Kosovo</i>	✓	✓	✓	✓
<i>Latvia</i>	✓	✓	✓	✓
<i>Lithuania</i>	✓	✓	✓	✓
<i>Luxembourg</i>	✓	✓	✓	✓
<i>Macedonia</i>	✓	✓	✓	✓
<i>Malta</i>	✓	✓	✓	✓
<i>Martinique</i>	✓	✓	✓	✓
<i>Montenegro</i>	✓	✓	✓	✓
<i>Netherlands</i>	✓	✓	✓	✓
<i>Norway</i>	✓	✓	✓	✓
<i>Poland</i>	✓	✓	✓	✓
<i>Portugal</i>	✓	✓	✓	✓
<i>Romania</i>	✓	✓	✓	✓
<i>Saint Barthelemy</i>	✓	✓	✓	✓
<i>Saint Martin</i>	✓	✓	✓	✓
<i>Slovakia</i>	✓	✓	✓	✓

Region	Cascade-500	Cascade-500-A	Cascade-500-W	Cascade-500-X
<i>Slovenia</i>	✓	✓	✓	✓
<i>Spain</i>	✓	✓	✓	✓
<i>Sweden</i>	✓	✓	✓	✓
<i>Switzerland</i>	✓	✓	✓	✓
<i>Turks and Caicos</i>	✓	✓	✓	✓
Australia	✓	✓	✓	✓
Brazil				
China	✓			
Colombia				✓
Costa Rica	✓			
<i>Egypt</i>				✓
<i>Hong Kong</i>	✓	✓		
India				✓
Israel				
Japan	✓			
Malaysia	✓			
<i>Mexico</i>				✓
<i>Myanmar</i>	✓	✓	✓	✓
New Zealand	✓	✓	✓	✓
Nigeria	✓			
Philippines	✓			
Qatar	✓			
Serbia				✓
Singapore	✓			
South Africa				
South Korea	✓			
Taiwan	✓			
Thailand	✓			
Turkey	✓	✓	✓	✓
United Arab Emirates				
United Kingdom	✓	✓	✓	✓
Vietnam				

NOTE: Some certifications may expire. Check back periodically to review the list of authorized countries.

6.2 FCC Statement

This device complies with Part 15 of the FCC Rules. Operation is subject to the following two conditions:

- (1) this device may not cause harmful interference, and
- (2) this device must accept any interference received, including interference that may cause undesired operation.

This equipment has been tested and found to comply with the limits for a Class B digital device, pursuant to part 15 of the FCC Rules. These limits are designed to provide reasonable protection against harmful interference in a residential installation. This equipment generates, uses and can radiate radio frequency energy and, if not installed and used in accordance with the instructions, may cause harmful interference to radio communications. However, there is no guarantee that interference will not occur in a particular installation. If this equipment does cause harmful interference to radio or television reception, which can be determined by turning the equipment off and on, the user is encouraged to try to correct the interference by one or more of the following measures:

- Reorient or relocate the receiving antenna
- Increase the separation between the equipment and the receiver
- Connect the equipment into an outlet on a circuit different from that to which the receiver is connected
- Consult the dealer or an experienced radio/TV technician for help

Changes or modifications not expressly approved by the party responsible for compliance could void the user's authority to operate the equipment.

The following information is provided in compliance with FCC regulations:

Name: Cascade-500 Series IoT Gateway

Model numbers: Cascade-500, Cascade-500-A, Cascade-500-W, and Cascade-500-X

Company Name: Rigado, Inc.

Company Address:

200 Hawthorne Ave. SE

Ste. D-400

Salem, OR 97301

Company Contact: support@rigado.com

6.3 IC Statement

This device contains license-exempt transmitter(s)/receiver(s) that comply with Innovation, Science and Economic Development Canada's license-exempt RSS(s). Operation is subject to the following two conditions:

- (1) This device may not cause interference.
- (2) This device must accept any interference, including interference that may cause undesired operation of the device.

L'émetteur/récepteur exempt de licence contenu dans le présent appareil est conforme aux CNR d'Innovation, Sciences et Développement économique Canada applicables aux appareils radio exempts de licence. L'exploitation est autorisée aux deux conditions suivantes :

- (1) L' appareil ne doit pas produire de brouillage;
- (2) L' appareil doit accepter tout brouillage radioélectrique subi, même si le brouillage est susceptible d' en compromettre le fonctionnement.

CAN ICES-3 (B) / NMB-3 (B)

This Class B digital apparatus complies with Canadian ICES-003.

(Cet appareil numérique de la Classe B conforme à la norme NMB-003 du Canada).

6.4 CE Statement

Rigado, Inc. declares that the Cascade-500, Cascade-500-A, Cascade-500-W, and Cascade-500-X comply with the essential requirements and other relevant provisions of Radio Equipment Directive 2014/53/EU and (RoHS 3) Directive 2015/863. A copy of the Declaration of Conformity is available on request and is also available at <https://www.rigado.com/certifications/>

Rigado, Inc.
200 Hawthorne Ave. SE
Ste. D-400
Salem, OR 97301
support@rigado.com

Article 4 of Regulation (EU) 2019/1020

Requires that products imported into the EU must include the name and contact information of an entity with a physical presence in the EU on the product, package, or included with the shipment. That entity, referred to as an economic operator, would be the primary contact point for any regulatory concerns an EU member state may have and would also need to be the one to hold a copy of the EU declaration of conformity that Rigado provides.

Rigado does not have a physical presence in the EU, nor does Rigado import product into the EU, and the responsibility of complying with this regulation lies with the entity shipping the product into the EU.

The full text of this regulation is available at <https://eur-lex.europa.eu/legal-content/EN/TXT/?uri=celex:32019R1020>, though article 4 is the relevant section.

The European Commission has issued a guideline document specific to article 4, and is available at <https://ec.europa.eu/docsroom/documents/44908/attachments/2/translations/en/renditions/pdf>

6.5 RF Exposure Statement

This equipment complies with the radiation exposure limits set forth for an uncontrolled environment. This equipment should be installed and operated with a minimum distance of 20cm between the radiator and any part of the human body.

6.6 Non-modification Warning Statement

Changes or modifications to this equipment that are not expressly approved by Rigado could void the user's authority to operate the equipment.

6.7 Taiwan (NCC) Statement

取得審驗證明之低功率射頻器材，非經核准，公司、商號或使用者均不得擅自變更頻率、加大功率或變更原設計之特性及功能。

低功率射頻器材之使用不得影響飛航安全及干擾合法通信；經發現有干擾現象時，應立即停用，並改善至無干擾時方得繼續使用。

前述合法通信，指依電信管理法規定作業之無線電通信。低功率射頻器材須忍受合法通信或工業、科學及醫療用電波輻射性電機設備之干擾。

應避免影響附近雷達系統之操作。

高增益指向性天線只得應用於固定式點對點系統。

6.8 Open Source

Open Source License attributions are available at <https://docs.rigado.com/docs/legal>.

6.9 Product Insert – Compliance Information

The following images show the regulatory insert provided within the product packaging.

FCC Statement
This device complies with part 15 of the FCC Rules. Operation is subject to the following two conditions: (1) This device may not cause harmful interference, and (2) this device must accept any interference received, including interference that may cause undesired operation.
This equipment has been tested and found to comply with the limits for a Class B digital device, pursuant to part 15 of the FCC Rules. These limits are designed to provide reasonable protection against harmful interference in a residential installation. This equipment generates, uses and can radiate radio frequency energy and, if not installed and used in accordance with the instructions, may cause harmful interference to radio communications. However, there is no guarantee that interference will not occur in a particular installation. If this equipment does cause harmful interference to radio or television reception, which can be determined by turning the equipment off and on, the user is encouraged to try to correct the interference by one or more of the following measures:
—Reorient or relocate the receiving antenna.
—Increase the separation between the equipment and receiver.
—Connect the equipment into an outlet on a circuit different from that to which the receiver is connected.
—Consult the dealer or an experienced radio/TV technician for help.

FCC Caution
Any changes or modifications not expressly approved by the party responsible for compliance could void the user's authority to operate this equipment.

RF Exposure Statement
This equipment complies with the radiation exposure limits set forth for an uncontrolled environment. This equipment should be installed and operated with a minimum distance of 20cm between the radiator and any part of the human body.

Canada (ISED) Statement
This device complies with Industry Canada license exempt RSS standard(s). Operation is subject to the following two conditions: (1) this device may not cause interference, and (2) this device must accept any interference, including interference that may cause undesired operation of the device. Under Industry Canada regulations, this radio transmitter may only operate using an antenna of a type and maximum (or lesser) gain approved for the transmitter by Industry Canada. To reduce potential radio interference to other users, the antenna type and its gain should be chosen so that the equivalent isotropically radiated power (e.i.r.p.) is not more than that necessary for successful communication.
Le présent appareil est conforme aux CNR d'Industrie Canada applicables aux appareils radio exempts de licence. L'exploitation est autorisée aux deux conditions suivantes: (1) l'appareil ne doit pas produire de brouillage, et (2) l'utilisateur de l'appareil doit accepter tout brouillage radioélectrique subi, même si le brouillage est susceptible d'en compromettre le fonctionnement. Conformément à la réglementation d'Industrie Canada, le présent émetteur radio peut fonctionner avec une antenne d'un type et d'un gain maximal (ou inférieur) approuvé pour l'émetteur par Industrie Canada. Dans le but de réduire les risques de brouillage radio électrique à l'intention des autres utilisateurs, il faut choisir le type d'antenne et son gain de sorte que la puissance isotrope rayonnée équivalente (p.i.r.e.) ne dépasse pas l'intensité nécessaire à l'établissement d'une communication satisfaisante.

Taiwan (NCC) Statement
取得審驗證明之低功率射頻器材，非經核准，公司、商號或使用者均不得擅自變更頻率、加大功率或變更原設計之特性及功能。
低功率射頻器材之使用不得影響飛航安全及干擾合法通信；經發現有干擾現象時，應立即停用，並改善至無干擾時方得繼續使用。
前述合法通信，指依電信管理法規動作業之無線電通信。低功率射頻器材須忍受合法通信或工業、科學及醫療用電波輻射性電機設備之干擾。
應避免影響附近雷達系統之操作。高增益指向性天線只得應用於固定式點對點系統。

RIGADO

Cascade-500 Series IoT Gateway

Important Safety Information
Before installing or operating this product, please review this insert and the information available online at: rigado.com/certifications

Unless otherwise indicated, this product is designed for indoor use. Use in dry locations only. Do not install near heat sources such as radiators, heat registers, stoves, or any other apparatus that produce heat.

Only use attachments and accessories specified by the Manufacturer.

Optimal Product Placement
This product uses wireless communications to operate. Do not install the product inside or near any large metal objects, or near sources of radio interference.

For more installation guidance, please visit docs.rigado.com or contact support@rigado.com

Disposal Guidelines
 **For professional users in the European Union**
If you wish to discard electrical and electronic equipment (EEE), please contact your dealer or supplier for further information.
For disposal in countries outside of the European Union
This symbol is only valid in the European Union (EU). If you wish to discard this product please contact your local authorities or dealer and ask for the correct method of disposal.

Product Regulatory Information
See inside this pamphlet for regulatory information unique to each model.
 Rigado, Inc. declares the radio equipment types Cascade-500, Cascade-500-A, Cascade-500-W, and Cascade-500-X are in compliance with Radio Equipment Directive 2014/53/EU. The full text of the EU Declaration of Conformity is available at the following address: <https://www.rigado.com/certifications/>
 The Cascade-500, Cascade-500-A, Cascade-500-W, and Cascade-500-X products are RoHS compliant per RoHS Recast Directive 2011/65/EU, and Directive (EU) 2015/863. For additional details, including any exemption information, please contact Rigado.
 Information provided in compliance with FCC regulations for Cascade-500 IoT series gateways with model numbers:
Cascade-500, Cascade-500-A, Cascade-500-W, and Cascade-500-X.

For open source license attributions, see:
docs.rigado.com/docs/legal

745-00003 v0N

Rigado, Inc.
200 Hawthorne Ave SE
Ste. D-400
Salem, OR 97301, USA
support@rigado.com



[rigado.com/
certifications](https://rigado.com/certifications)

Cascade-500

Regulatory Model/型号/型號: Cascade-500
 Product Type/产品名称: Gateway/网关/網關
 Input/輸入/輸入: DC 5V/2A or PoE (DC 48V/0.5A)
 Manufacturer/制造商/製造商: Rigado, Inc.
 Country of Origin/原产地/原產地: China



Contains FCC ID: 2AA9B11 N6C-SDPAC
 Contains IC: 12208A-11 4908A-SDPAC
 CE UK CA RoHS
 5.2G band: この製品は屋内においてのみ使用可能です

Complies with IMDA Standards DA105282
 sutel 03699-2021
 NTC Type Approved No: ESD-RCE-2126036
 CCAJ22LP1680T5
 CMIIT ID: 2021AJ17313

R-R-Rgd-Cascade-500
 Rigado, Inc. Cascade Gateway
 Model Name: Cascade-500
 Year of Manufacture: 2025
 Manufacturer: Rigado, Inc.
 Country of Origin: China
 D3E471 RoHS

Connection and use of this communications equipment is permitted by the Nigerian Communications Commission



nans.
 เครื่องวิทยุคมนาคมนี้ ได้รับยกเว้น ไม่ต้องได้รับใบอนุญาตให้มี ใช้ซึ่งเครื่องวิทยุคมนาคม หรือตั้งสถานีวิทยุคมนาคมตามประกาศ กสทช. เรือง เครื่องวิทยุคมนาคม และสถานีวิทยุคมนาคมที่ได้รับยกเว้นไม่ต้องได้รับใบอนุญาตวิทยุคมนาคม ตามพระราชบัญญัติวิทยุคมนาคม พ.ศ. 2498
 nans. โทรคมนาคม
 กำกับดูแลเพื่อประชาชน
 Call Center 1200 (InSWIS)

Cascade-500-A

Regulatory Model/型号/型號: Cascade-500-A
 Product Type/产品名称: Gateway/网关/網關
 Input/輸入/輸入: DC 5V/2A or PoE (DC 48V/0.5A)
 Manufacturer/制造商/製造商: Rigado, Inc.
 Country of Origin/原产地/原產地: China

Contains FCC ID: 2AA9B11 N6C-SDPAC
 Contains IC: 12208A-11 4908A-SDPAC
 CE UK CA RoHS

Cascade-500-W

Regulatory Model/型号/型號: Cascade-500-W
 Product Type/产品名称: Gateway/网关/網關
 Input/輸入/輸入: DC 5V/2A or PoE (DC 48V/0.5A)
 Manufacturer/制造商/製造商: Rigado, Inc.
 Country of Origin/原产地/原產地: China

Contains FCC ID: 2AA9B11 N6C-SDPAC QIPPLS62-W
 Contains IC: 12208A-11 4908A-SDPAC 7830A-PLS62W
 CE UK CA RoHS

Cascade-500-X

Regulatory Model/型号/型號: Cascade-500-X
 Product Type/产品名称: Gateway/网关/網關
 Input/輸入/輸入: DC 5V/2A or PoE (DC 48V/0.5A)
 Manufacturer/制造商/製造商: Rigado, Inc.
 Country of Origin/原产地/原產地: China

Contains FCC ID: 2AA9B11 N6C-SDPAC QIPPLS63-W
 Contains IC: 12208A-11 4908A-SDPAC 7830A-PLS63W
 CE UK CA RoHS
 IFC: TERICA23-42593

The Bluetooth® word mark and logos are registered trademarks owned by Bluetooth SIG, Inc. and any use of such marks by Rigado is under license. Other trademarks and trade names are those of their respective owners.